



TUNNEL & UNDERPASS LUMINAIRES





ROTTA

www.pelsan.com.tr

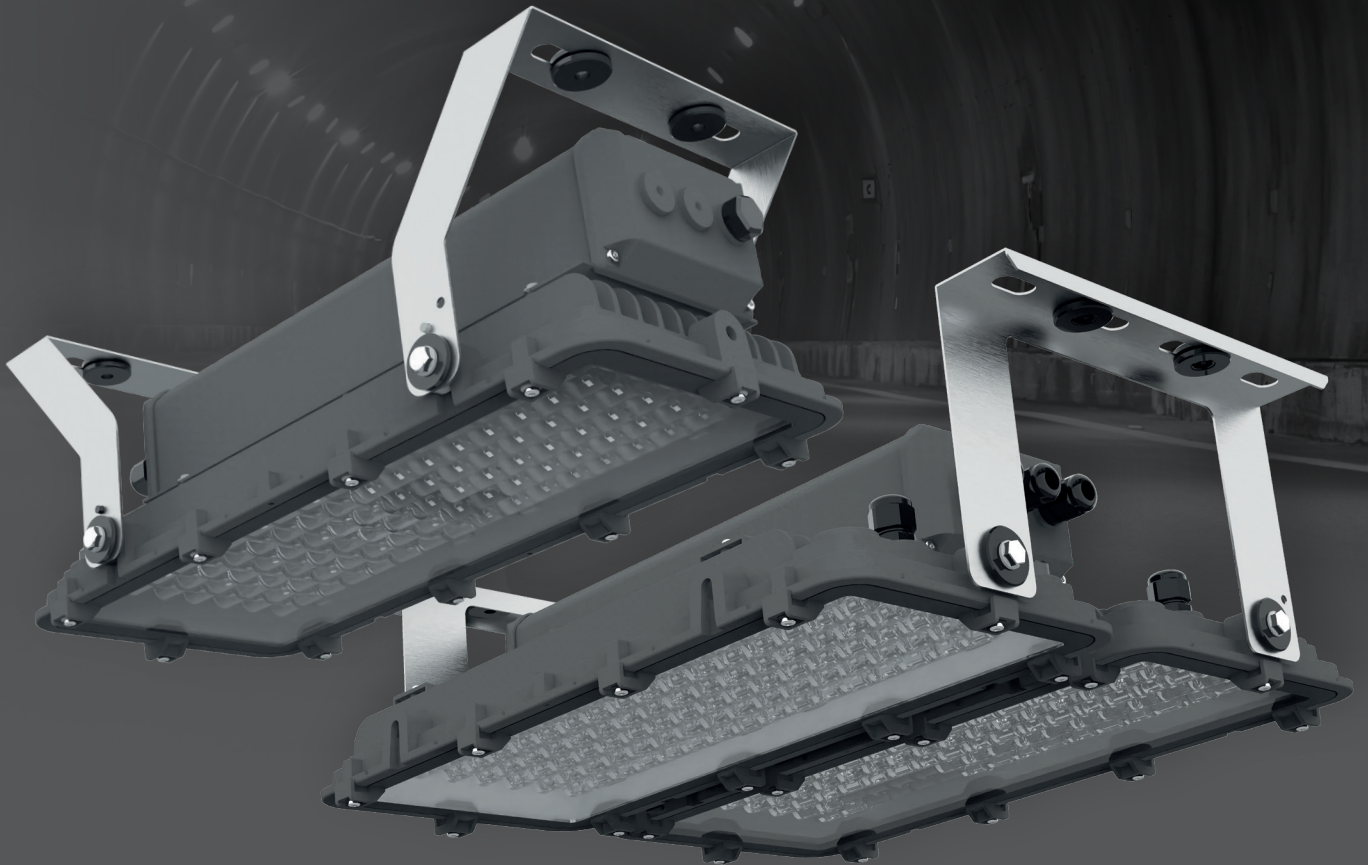
ROTTA





-  Wide range of optics
-  Flexible power variety
-  High quality and robust materials
-  Compact, lightweight and easy to install
-  Long-lasting performance



Superior Thermal Management

It uses the natural movement of air by convection of heat of the critical electrical components. It takes advantage of the constant wind flow in the tunnel to manage the heat and is further improved by the venturi effect. LED Driver is supplied in an external housing to guarantee a minimum distance between the two major heat sources, helping to optimize thermal management. Excellent thermal management for high efficiency due to custom design cooling ribs

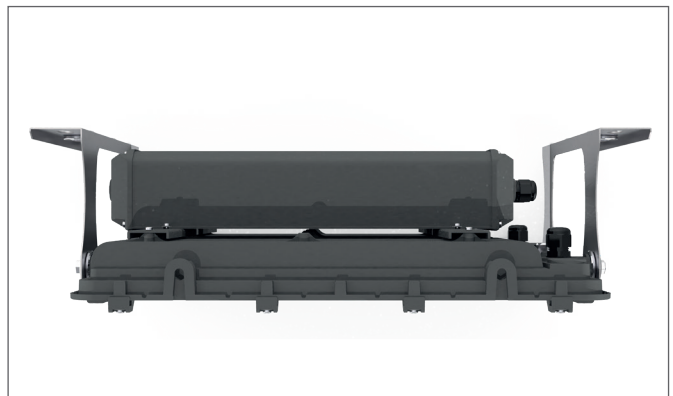
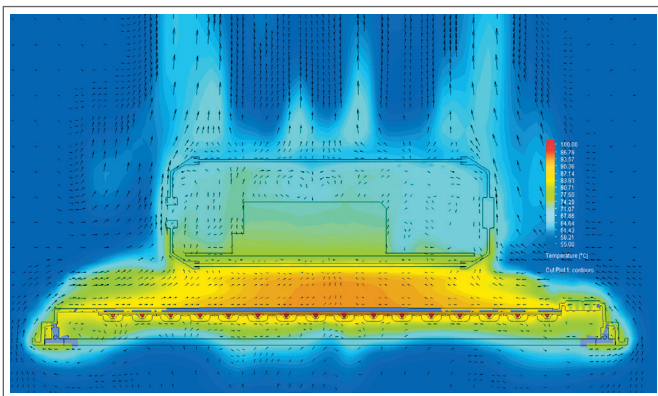

Compact, Lightweight and Easy To Install

If tunnel operators have to close the tunnel because of technical problems the damage in costs because of the closure is much higher than an add on in the investment. In these and similar cases, quick installation prevents extra costs that may occur. Rotta provides quick and easy installation to eliminate waste of time.



Fixed Bracket

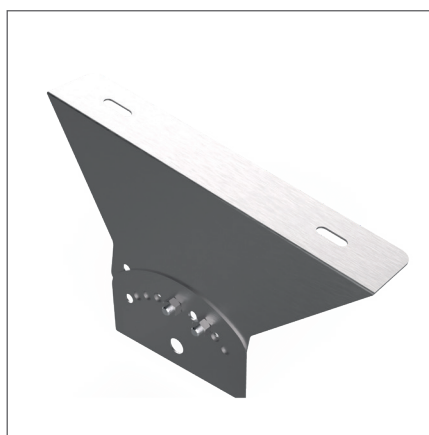

Adjustable Bracket

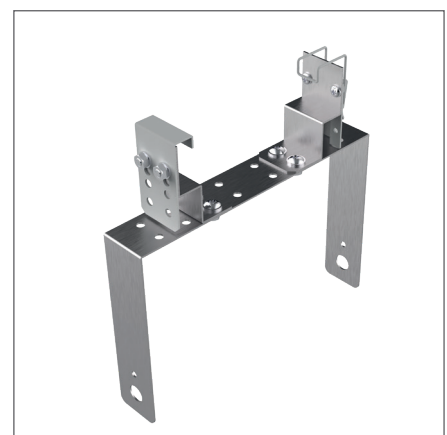

Toolles Bracket

High Quality and Robust Materials

Tunnel lighting fixtures have some challenges to deal with. Salt water flowing from the rocks due to leaks, emissions from the car, galvanic effect (Corrosion), pressure changes due to temperature differences and stresses due to condensation are the main difficulties.

Rotta dispels all difficulties via high quality and robust material and ensure long life



High Efficacy and Wide Range of Optics

Correct optical design and energy saving are important criteria for tunnel lighting design. With the wide optical options offered by Rotta, it meets all the features required for a correct lighting design. It offers maximum energy savings with up to 165lm/W efficacy.

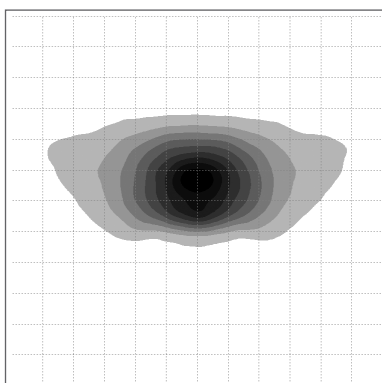

Asymmetrical

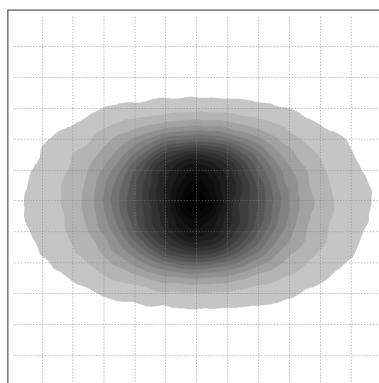

Symmetrical

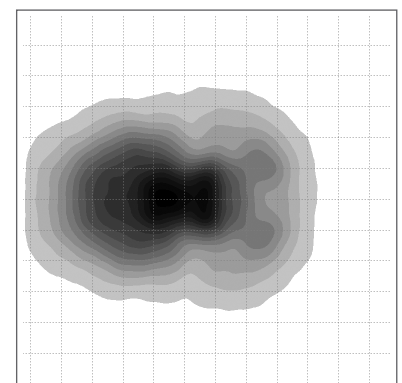

CounterBeam

ACCESS ZONE

Not within the tunnel itself, this is the stretch of road leading to its entrance. From this zone, drivers must be able to see into the tunnel in order to detect possible obstacles and to drive into the tunnel without reducing speed. The driver's capacity to adapt in the access zone governs the lighting level in the next part of the tunnel.

THRESHOLD ZONE

This zone is equal in length to the 'stopping distance'

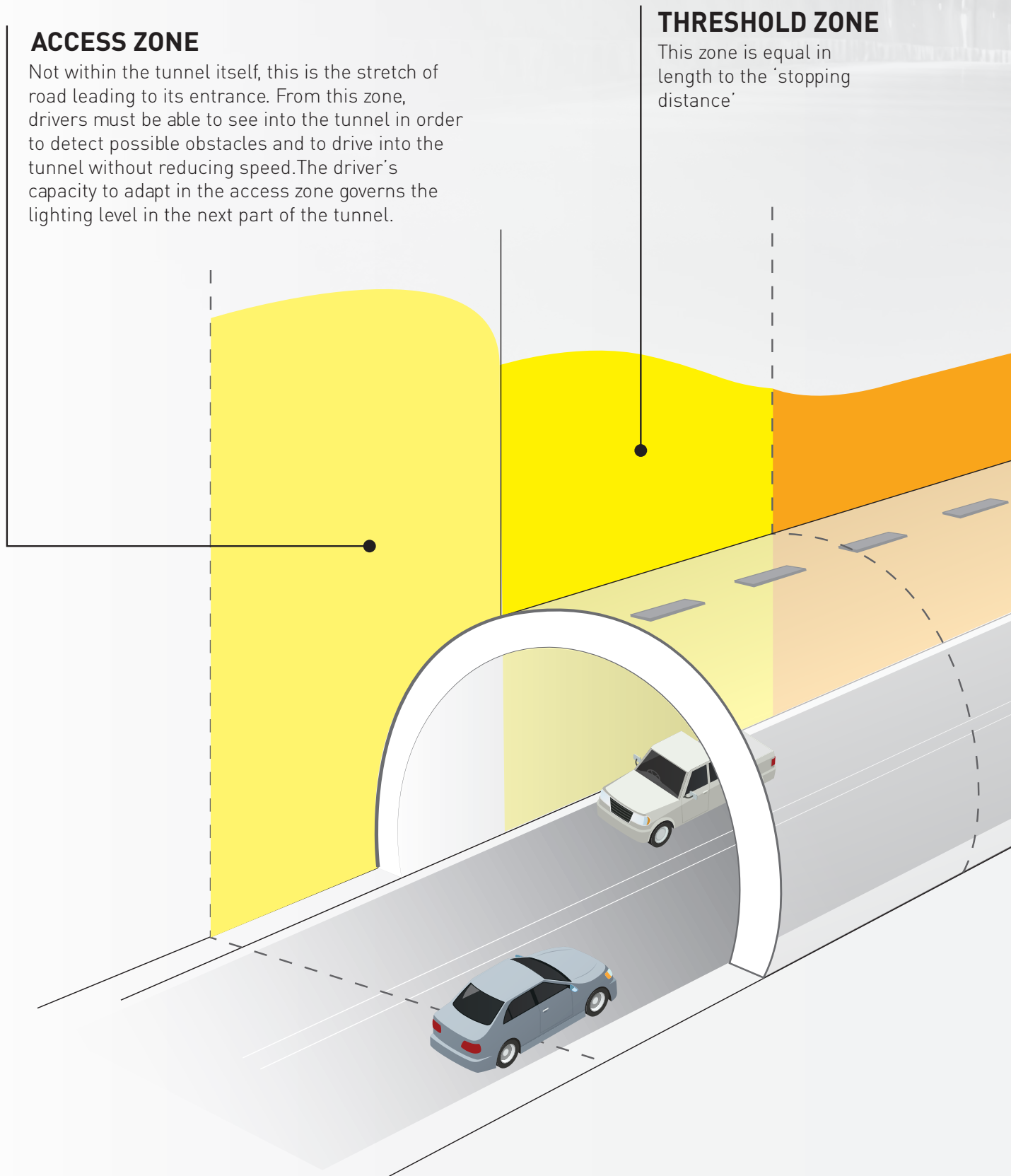

TRANSITION ZONE

Over the distance of the transition zone, luminance is reduced progressively to reach the level required in the interior zone.

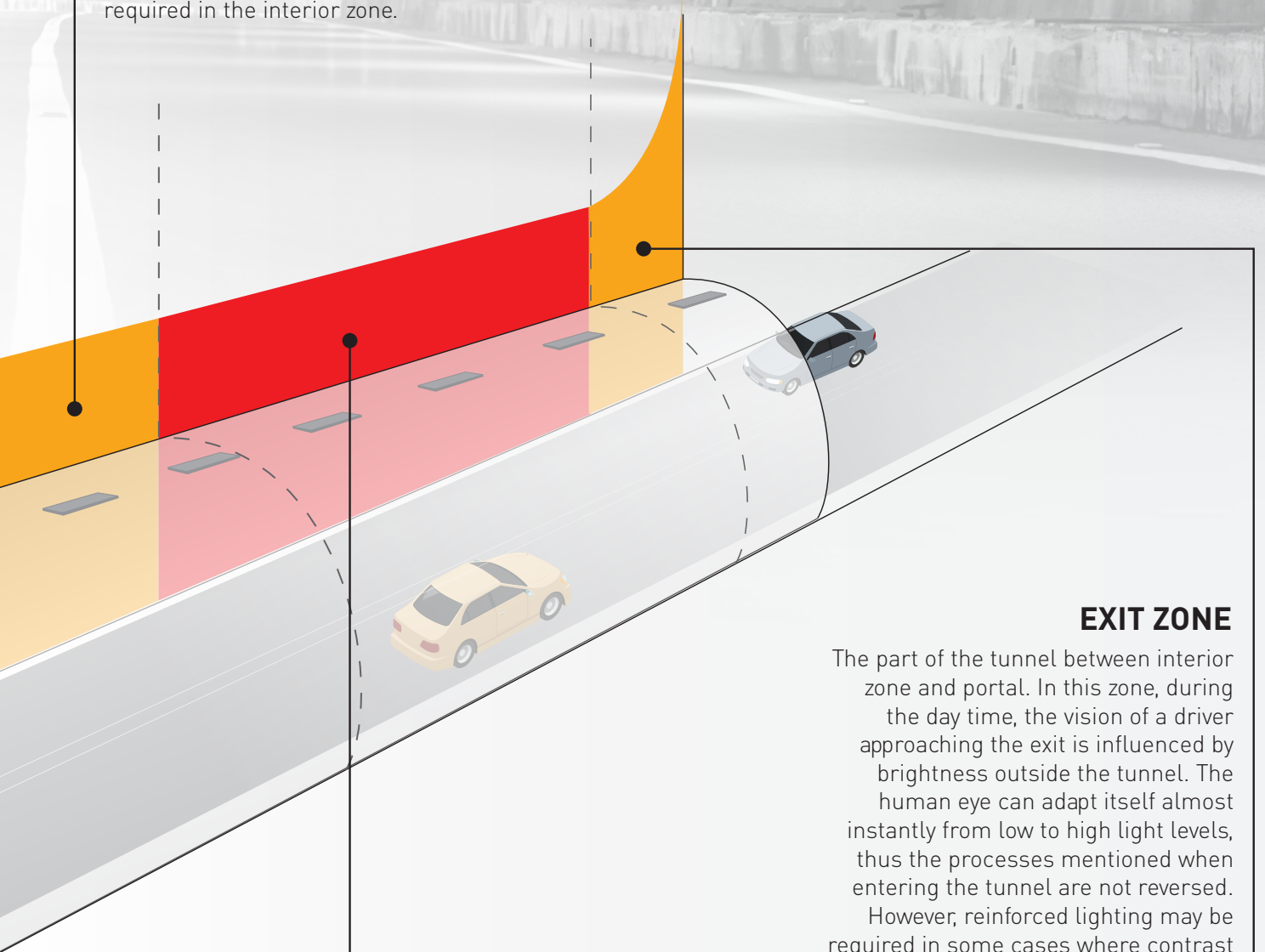

INTERIOR ZONE

This is the area between transition and exit zones, often the longest stretch of tunnel. Lighting levels are linked to the speed and density of traffic

EXIT ZONE

The part of the tunnel between interior zone and portal. In this zone, during the day time, the vision of a driver approaching the exit is influenced by brightness outside the tunnel. The human eye can adapt itself almost instantly from low to high light levels, thus the processes mentioned when entering the tunnel are not reversed. However, reinforced lighting may be required in some cases where contrast is needed in front of or behind the driver when the exit is not visible or when the exit acts as entrance in case of emergency or maintenance works where part of a twin tunnel may be closed.

Symmetrical and Asymmetrical Lighting

Used generally for transition and interior zones for long tunnels, and in short tunnels, or low speed tunnels for all zones. Asymmetrical lighting can also be a means of reinforcing the luminance level in one way tunnels.

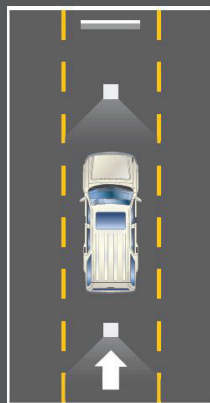
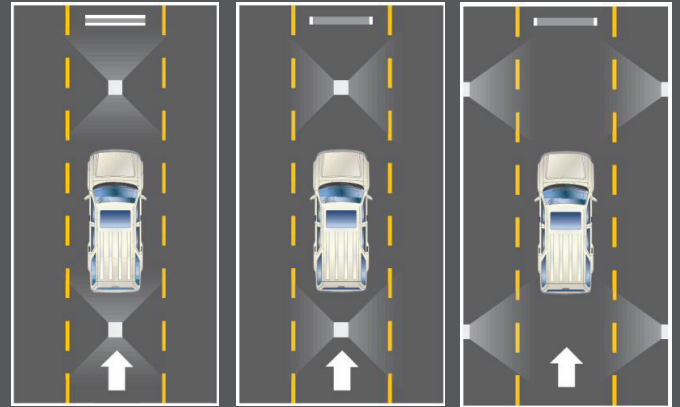

Counter Beam Lighting

To reinforce the luminance level and at the same time accentuate the negative contrast of potential obstacles. Counter beam lighting is achieved with asymmetrical light distribution facing into the traffic flow, both in the direction of the on coming driver and in the run of the road. The beam stops sharply at the vertical plane passing through the luminaire. No light is directed with the flow of traffic. This generates negative contrast and enhances visual adaptation.

Pro Beam Lighting

In some circumstances, positive contrast must be reinforced, often in the exit zone where the exit is visible. In these cases, asymmetric light distribution is used in the same way as counter beam but with direction of the traffic and is called 'pro beam'. In dual carriage way tunnels, counter beam at entrance can act as pro beam at exit.

This technique is not recommended as the road luminance is very low, creating too big a disparity between the exit zone and the parting zone.

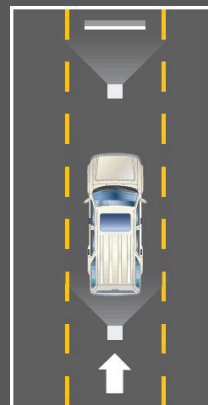

Lighting systems for tunnels need to satisfy criteria for daytime, nighttime, and emergency situations. Requirements are determined based upon several factors:

- Approach scene, road grade of approach, and materials around approach
- Average annual daily traffic volume
- Posted speed limit
- Compass orientation of the tunnel's approach
- Direction of travel – one direction only (divided tunnel) or in two direction (undivided tunnel)

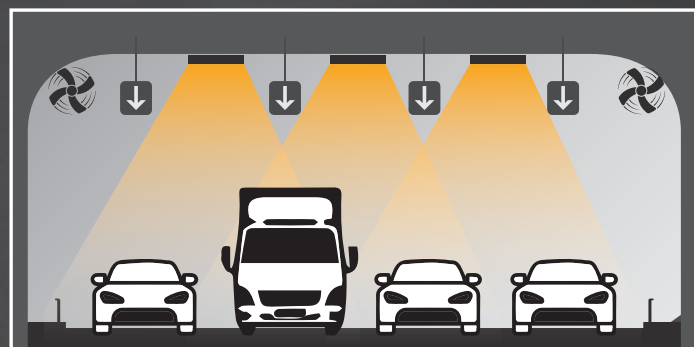
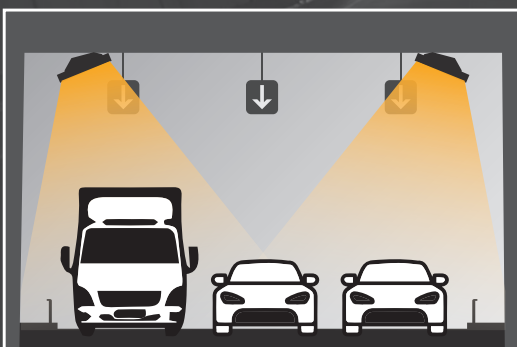
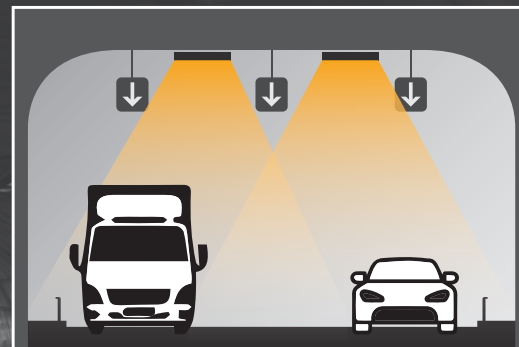
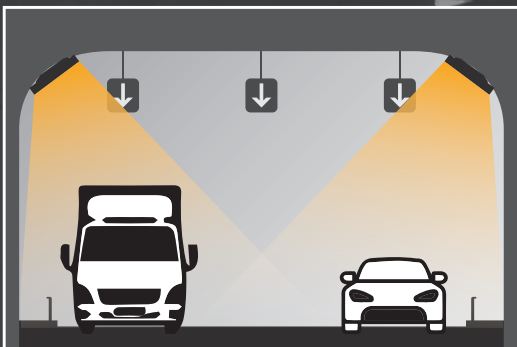
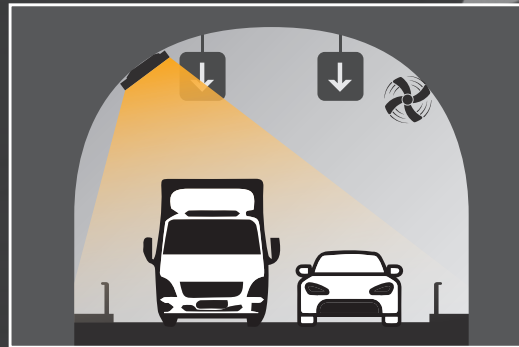
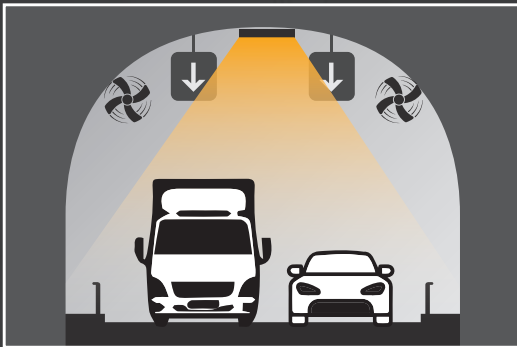



Mechanical Specifications

Body	Die-cast, marine grade aluminum housing
IP Rating	IP66
IK Rating Body	IK09
Standard Product Colour	RAL 7043
Mounting Type	Direct mounting on ceiling, wall or cable tray
Bracket	Sabit Braket (FB)
Gasket	Silicone
Fasteners	Stainless steel (AISI 304)
Finishing	Electrostatic powder coating
Light Source Replaceable	Yes
Serviceability Class	Luminaire is equipped with serviceable parts (when applicable): LED board, driver, control units, surge protection device, optics, front cover and mechanical parts



Electrical Specifications

Input Voltage	220-240Vac
Frequency	50-60Hz
Class	I
Driver Lifetime	≥100.000h
Power Factor	>0,95
Operating Temperature	-40°C / +55°C
Driver Surge Protection	10/6kV
Control	On/Off, (0)1-10V, DALI, StepDIM
Cable	1 mt. of rubber cable



Optical Specifications

Light Source	Power LED
Lens / Reflector	PMMA Lens
Diffuser	Tempered Glass
Colour Temperature	3000K CRI70, 4000K CRI70
Photobiological Risk Group	RG1
Lifetime	>102000h
Colour Consistency (SDCM)	MacAdam ≤ 5-Step



Optionals

Input Voltage	120-277VAC
Class	II
External surge protection	10kV or 20kV
Light output	CLO (Constant light output)
Through Wiring	Two cable entry
Cable	Halogen-free cable
Product colour	Custom colour (Please specify RAL code)
Finishing	Polyester powder coating with anodisation (C5-CX according to the ISO 9223-2012 std.)
Fasteners	A4 Stainless steel (AISI 316)
Brackets	Adjustable Bracket (AB), Latch Bracket (LB), Custom Bracket (CB)

Luminaire	Current (mA)	Power (W)	Luminaire Luminous Flux (lm)	Efficacy (lm/W)	 m ²	Dimensions (mm) axbxc	Weight	Pcs Pack	Package Vol. (m ³)	Package Weight (kg)
ROTTA 24 LED	700	52	6380-8080	122-155	0,116m ²	522x258x206	6,1	1	0,035	7,7
ROTTA 48 LED	500-700	74-103	9480-16000	120-162	0,116m ²	522x258x206	6,7	1	0,035	8,8
ROTTA 72 LED	500-700	110-154	14070-23763	122-161	0,116m ²	522x258x206	7	1	0,035	8,6
ROTTA 96 LED	500-700	148-205	18820-30761	118-156	0,116m ²	522x258x206	8	1	0,035	9,6
ROTTA 144 LED	500-700	220-308	28140-47526	122-162	0,241m ²	629x476x195	13,4	1	0,067	15
ROTTA 192 LED	500-700	296-410	36440-61522	118-156	0,241m ²	629x476x195	14	1	0,067	15,6



Pelsan



All your lighting needs in one adress.

www.pelsan.com.tr

info@pelsan.com.tr | export@pelsan.com.tr

HEAD OFFICE

Çerkeşli O.S.B.
İmes 5. Cadde No:12
Dilovası / Kocaeli - TÜRKİYE



[/PelsanAydinlatma](#)



[pelsan-aydinlatma](#)



[pelsan aydinlatma](#)



[/pelsanaydinlatma](#)



[/PelsanLight](#)

P : +9(0850) 460 75 76

F : +9(0216) 364 60 15